

Covariance Analysis of a Vector Tracking GPS Receiver based on MMSE Multiuser Detection

T. Shojaezand¹, Gh. Mohamadkhani¹, P. Azmi² and Sh. Amiri¹

¹ Department of Electrical Engineering and Information Technology, IROST (Iranian Research Organization for Science and Technology), Tehran, Iran

² Faculty of Electrical & Computer Engineering, Tarbiat Modares University, Tehran, Iran
t.shojaezand@gmail.com, gh.mohamadkhani17@gmail.com, pazmi@modares.ac.ir, amiri@irost.ir

Corresponding author: Gh. Mohamadkhani

Abstract- In high dynamic conditions, using vector tracking loops instead of scalar tracking loops in GPS receivers is proved as an efficient method to compensate the performance. The Minimum Mean Squared Error detector as a multiuser detector is applied in the vector tracking loop for more reliability and efficiency. The Kalman filter does the two tasks of tracking and extracting the navigation data after applying the multiuser detection on the correlator outputs. The covariance analysis is performed to study the effect of applying a multiuser detector along with a vector tracking loop against the conventional one. The covariance analysis is performed and the variance in the pseudorange-rate estimates produced by the two architectures of conventional vector tracking and the one with multiuser detector are used as the performance criteria. The steady state, state covariance of the Kalman filter of vector tracking loop is calculated. Comparing the pseudorange rate variances obtained from covariance analysis of each method shows improved performance of the new joint receiver of vector and multiuser detector.

Index Terms- Covariance Analysis, GPS, MMSE, Vector Tracking.

I. INTRODUCTION

Vector tracking loops in Global Positioning System (GPS) receivers are powerful method in special situations such as high dynamic and low Signal to Noise ratios (SNRs). GPS receivers in vector mode use a Kalman filter as the main part and the two tasks of tracking the signal and estimating the position, etc are done simultaneously in this central filter. The vector tracking method is one of the best methods that is mostly used in this condition along with some other methods such as using phase and frequency tracking loops together, a Kalman filter to help the tracking loop, and some other methods stated in references [1]–[4].

In GPS systems like the other Code Division Multiple Access (CDMA) systems we encounter some problems, such as multiple access interference and near-far problems. CDMA systems use multiuser detectors in the receiver as a conventional way to overcome these issues. So it seems that applying a kind of multiuser detector beside the vector tracking method will help the GPS receiver in high dynamic conditions for more accuracy and high sensitivity. On the other hand as stated in some papers [5]-[7], cross correlation mitigation of GPS signals is a way to improve the sensitivity and precision of the tracking, and of course multiuser techniques help the cross correlation mitigation process in this regard. Minimum Mean Squared Error (MMSE) is a conventional multiuser detector in CDMA systems, that was used along with vector tracking loop in the software GPS receiver that presented in [8] to have its advantages in high dynamic situations.

In the stated system of [8], we investigated the performance of the new proposed system by calculating the variance of the parameter of code phase error that is an important parameter for calculating the estimated pseudo-range error. Here in this paper we considered the performance of the system in another way and with another important parameter of state covariance of the Kalman filter that shows the error covariance matrix of the system. Actually we study the effect of the new added block in the Kalman filter. The Kalman filter has a key role in designing vector tracking loops in GPS receivers as it helps to combine the two tasks of signal tracking and position/velocity estimation into one algorithm. The state covariance of the Kalman filter along with process noise variances of the system are the base subject to compare the performance of the two architectures in concern.

A covariance analysis of the Kalman filter is used to evaluate the effectiveness of the proposed receiver system of reference [8] and compare the performance of the system with a conventional vector tracking without applying any multiuser detector. The variances of the predicted pseudo-range rates are then compared. Variance is defined as a measure of risk an investor might assume when purchasing a specific security. So by comparing the variances of a basic parameter of the two methods we investigate the risk we encounter when adding an additional block to the receiver tracking loop.

The paper is organized as follows:

The second section fully describes the system with block diagram and the equations. Then the simulation that was performed is described in section III. The two other sections include the results and conclusions.

II. SYSTEM DESCRIPTION

The tracking loop of the GPS receiver is our discussion subject. The tracking loop is a vector tracking loop that is joined with a MMSE block of multiuser detector. Fig. 1 shows the diagram of a vector tracking loop joined with a MMSE multiuser detector block.

The vector tracking loop, as explained in many articles [1], [9] and [10], has a central filter that

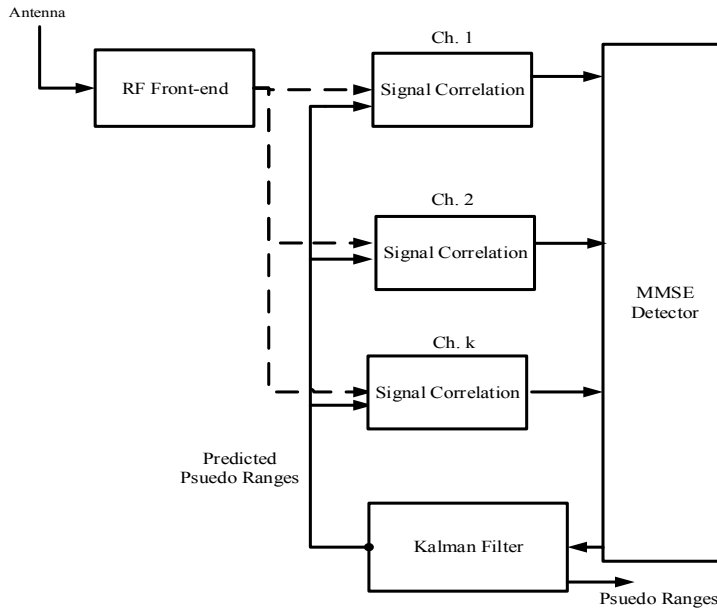

Fig. 1. Block diagram of a typical vector tracking loop Proposed method block diagram [8]

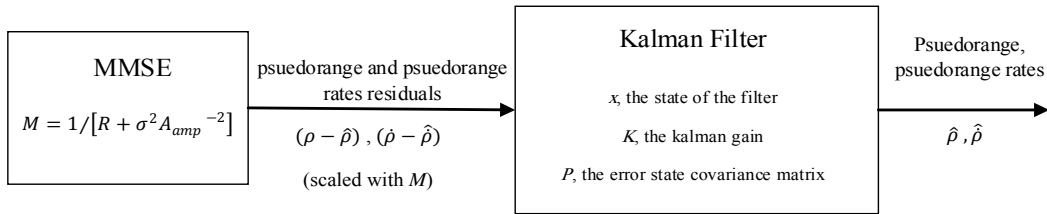

Fig. 2. Detailed block diagram of the Kalman filter

does the two tasks of tracking and estimating the position simultaneously. As shown in the Fig. 1, at the input of each channel, the state of the Kalman filter (predicted pseudo-range) enters the tracking loop, and the outputs of each channel (pseudo-range residuals) are used as corrections of the state of the Kalman filter. It means that the states of the Kalman filter are used to control the code and carrier Numerically Controlled Oscillator's (NCO) of each tracking loop channel and then the output of correlators in each channel is used to correct the Kalman filter state, and this process makes a vectortracking loop.

This Kalman filter has the position and velocity as its inputs and returns the pseudo-range and pseudo-range rates residuals as the output, Fig. 2.

When combining the vector tracking loop with a MMSE block, the outputs of correlators are first feed to the MMSE block and the MMSE output is used as the input of the Kalman filter.

The estimate of the transmitted bits in a MMSE detector is [11]:

$$y_{in} = R.A_{amp}.b + n \quad (1)$$

$$[R + \sigma^2 A_{amp}^{-2}]^{-1}.y_{in} = b \quad (2)$$

$$A_{amp} = diag \{A_1 \dots A_k\} \quad (3)$$

$$R = \begin{bmatrix} 1 & \rho_{12} & \dots & \rho_{1k} \\ \rho_{21} & 1 & \dots & \rho_{2k} \\ \vdots & \vdots & \ddots & \vdots \\ \rho_{k1} & \rho_{k2} & \dots & 1 \end{bmatrix} \quad (4)$$

Where y_{in} is the vector of inputs of the detector, R assumes to be the cross-correlation matrix of signature codes, A_{amp} is the amplitude matrix of the user's received signals, and b is the vector of the transmitted bits and σ^2 is the variance of zero-mean Gaussian noise. So the MMSE block is specified by the M matrix as below

$$M = 1/[R + \sigma^2 A_{amp}^{-2}] \quad (5)$$

The Kalman Filter here is specified with the pseudo-range state formulas. The pseudo-range (range with error) and pseudo-range rate errors are the actual states of the pseudo-range state filter [12]. In the more general vector case, the performance of the Kalman filter estimate is characterized by an error covariance matrix denoted as P_k [13] and defined by

$$P_k = E\{e_k.e_k^T\} = E\{(x_k - \hat{x}_k).(x_k - \hat{x}_k)^T\} \quad (6)$$

$$x = \begin{bmatrix} \rho \\ \dot{\rho} \end{bmatrix} \quad (7)$$

Where ρ and $\dot{\rho}$ are the pseudo-range and pseudo-range rate respectively. So the state vector of the Kalman filter is

$$e = \begin{bmatrix} \rho_1 \\ \dot{\rho}_1 \\ \vdots \\ \rho_N \\ \dot{\rho}_N \end{bmatrix} - \begin{bmatrix} \hat{\rho}_1 \\ \hat{\dot{\rho}}_1 \\ \vdots \\ \rho_N \\ \hat{\dot{\rho}}_N \end{bmatrix} \quad (8)$$

Where ρ and $\dot{\rho}$ are the actual pseudo-range and pseudo-range rates respectively and the terms $\hat{\rho}$ and $\hat{\dot{\rho}}$ are the predictions quantity.

The state system model is

$$x = A.\dot{x} + B_{dyn}.w_{dyn} + B_{clk}.w_{clk} \quad (9)$$

Where A is the state transition matrix,

$$A = \begin{bmatrix} \alpha & \alpha_{2 \times 2} & \dots & 0_{2 \times 2} \\ 0_{2 \times 2} & \alpha & & \vdots \\ \vdots & & \ddots & \vdots \\ 0_{2 \times 2} & \dots & \dots & \alpha \end{bmatrix}$$

(10)

$$\alpha = \begin{bmatrix} 1 & T \\ 0 & 1 \end{bmatrix} \quad (11)$$

B_{clk} and w_{clk} are the clock process noise terms and statistics,

$$B_{clk} = \begin{bmatrix} I_{2 \times 2} \\ \vdots \\ I_{2 \times 2} \end{bmatrix} \quad (12)$$

$$w_{clk} = \begin{bmatrix} w_b \\ w_d \end{bmatrix} \quad (13)$$

$$E\{w_{clk}.w_{clk}^T\} = \begin{bmatrix} \sigma_b^2 & 0 \\ 0 & \sigma_d^2 \end{bmatrix} \quad (14)$$

The values for σ_b^2 and σ_d^2 are based on the rule of thumb numbers for a temperature compensated crystal oscillator (TCXO). B_{dyn} and w_{dyn} are the receiver dynamics process noise terms and statistics.

$$B_{dyn} = \begin{bmatrix} 0 & 0 & 0 \\ a_{x,1} & a_{y,1} & a_{z,1} \\ \vdots & \vdots & \vdots \\ 0 & 0 & 0 \\ a_{x,N} & a_{y,N} & a_{z,N} \end{bmatrix} \quad (15)$$

$$w_{dyn} = \begin{bmatrix} w_x \\ w_y \\ w_z \end{bmatrix} \quad (16)$$

$$E\{w_{dyn}.w_{dyn}^T\} = \begin{bmatrix} \sigma_x^2 & 0 & 0 \\ 0 & \sigma_y^2 & 0 \\ 0 & 0 & \sigma_z^2 \end{bmatrix} \quad (17)$$

Where $a_{x,i}$, $a_{y,i}$ and $a_{z,i}$ are the components of the line-of-sight unit vector from the position of the receiver to the position of the i th available satellite.

III. SIMULATION

In this paper, we perform a covariance analysis to compare a regular vector tracking loop and a vector tracking loop joined with the multiuser detector. To perform the covariance analysis, we calculated the of the steady state, state covariance for the two methods. The covariance matrix P is calculated through the Kalman filter formulas as follows [14],[15]:

$$K = P'_k \cdot H^T \cdot (H \cdot P'_k \cdot H^T + G)^{-1} \quad (18)$$

$$P_k = (I - K_k \cdot H) \cdot P'_k \quad (19)$$

$$P_{k+1} = A \cdot P_k \cdot A^T + Q \quad (20)$$

P'_k is the prior estimate of P_k at time k , K is the Kalman gain, G is the measurement noise covariance that will be defined in the following paragraph and H is the transition matrix between the state vector and measurement vector and here is defined as $I_{2N \times 2N}$ where N is the number of satellites.

The measurement noise covariance as a function of $C/N0$ ratio is [16]:

$$G = E\{v_k \cdot v_k^T\} = \begin{bmatrix} \sigma_\rho^2 & 0 \\ 0 & \sigma_\rho^2 \end{bmatrix} \quad (21)$$

$$\sigma_\rho^2 = \frac{\beta^2}{2(T \cdot 10^{(C/N0)/10})^2} + \frac{\beta^2}{4T \cdot 10^{(C/N0)/10}} \quad (\text{meters}) \quad (22)$$

$$\beta = 293.3 \quad (\text{meters}) \quad (23)$$

$$\sigma_\rho^2 = \left(\frac{2}{(T \cdot 10^{(C/N0)/10})^2} + \frac{2}{4T \cdot 10^{(C/N0)/10}} \right) \cdot \gamma \quad (24)$$

$$\gamma = \left(\frac{c}{\pi \cdot f_{L1} \cdot T} \right)^2 \quad (25)$$

The covariance of the process noises w_{dyn} and w_{clk} are [12]

$$Q = E\{w_k w_k^T\} \quad (26)$$

$$Q_{clk} = \begin{bmatrix} Q^c & \dots & Q^c \\ \vdots & \ddots & \vdots \\ Q^c & \dots & Q^c \end{bmatrix} \quad (27)$$

$$Q^c = \begin{bmatrix} \sigma_b^2 T + \sigma_d^2 \frac{T^3}{3} & \sigma_d^2 \frac{T^2}{2} \\ \sigma_d^2 \frac{T^2}{2} & \sigma_d^2 T \end{bmatrix} \quad (28)$$

$$Q_{dyn} = \begin{bmatrix} Q_{1,1}^d & Q_{1,1}^d & \cdots & Q_{1,1}^d \\ Q_{2,1}^d & Q_{2,2}^d & \cdots & Q_{2,N}^d \\ \vdots & \vdots & \ddots & \vdots \\ Q_{N,1}^d & Q_{N,2}^d & \cdots & Q_{N,N}^d \end{bmatrix} \quad (29)$$

$$Q_{i,j}^d = \begin{bmatrix} \beta_{i,j} \frac{T^3}{3} & \beta_{i,j} \frac{T^2}{2} \\ \beta_{i,j} \frac{T^2}{2} & \beta_{i,j} T \end{bmatrix} \quad (30)$$

$$\beta_{i,j} = [\sigma_x^2 a_{x,i} a_{x,j} + \sigma_y^2 a_{y,i} a_{y,j} + \sigma_z^2 a_{z,i} a_{z,j}] \quad (31)$$

$\beta_{i,j}$ is the dot product of the line of sight vectors for i th and j th satellites. For the MMSE joined method, the state of the Kalman filter that enters the tracking loop will be changed as follows:

$$A_{new} = A.M \quad (32)$$

Where M shows the MMSE block role that was previously defined in equation (5) and is repeated here as:

$$M = [R + \sigma^2 A_{amp}^{-2}]^{-1} \quad (33)$$

Now we can calculate the covariance of the error states as the function of $C/N0$ for the two methods, and so we can compare the covariances across $C/N0$ changing. The parameters are set as below:

σ_x , σ_y and σ_z are all set to $10 \text{ m}^2/\text{s}^4$ and T , the predetection integration time is set to 20 ms . The data related to the constellation of the satellites and the satellites line of sight vectors of a_x , a_y and a_z are derived from GPS received data with 9 satellites in view [17] as follows:

The Pseudo Random Noise (PRN) of visible satellites are satellite number 4, 8, 11, 13, 17, 25, 26, 27 and 28 and the line of site vectors are stated in Table I.

IV. RESULTS

The covariance analysis was performed in a MATLAB based program that calculates the error state covariances of the two explained methods for a range of $C/N0$ ratios. $C/N0$ is usually expressed in decibel-Hertz (dB-Hz) and refers to the ratio of the carrier power and the noise power per unit

TABLE I. THE VISIBLE SATELLITES AND SATELLITES LINE OF SIGHT VECTORS.

| PRN | a_x | a_y | a_z |
|-----|-------------|-------------|------------|
| 4 | 0.316199210 | 0.435193118 | -0.8429857 |

| | | | |
|----|--------------|--------------|------------|
| 8 | 0.018343402 | 0.790366768 | 0.61235928 |
| 11 | -0.604302232 | 0.647242197 | 0.46464645 |
| 13 | 0.001384195 | 0.57490726 | -0.8182174 |
| 17 | 0.632049540 | 0.75145293 | 0.18929308 |
| 25 | -0.361358908 | 0.923876856 | -0.1259813 |
| 26 | 0.6998733785 | -0.12472686 | 0.70329258 |
| 27 | -0.185419649 | 0.961945654 | 0.20069905 |
| 28 | 0.3071187889 | 0.3359944443 | 0.89038519 |

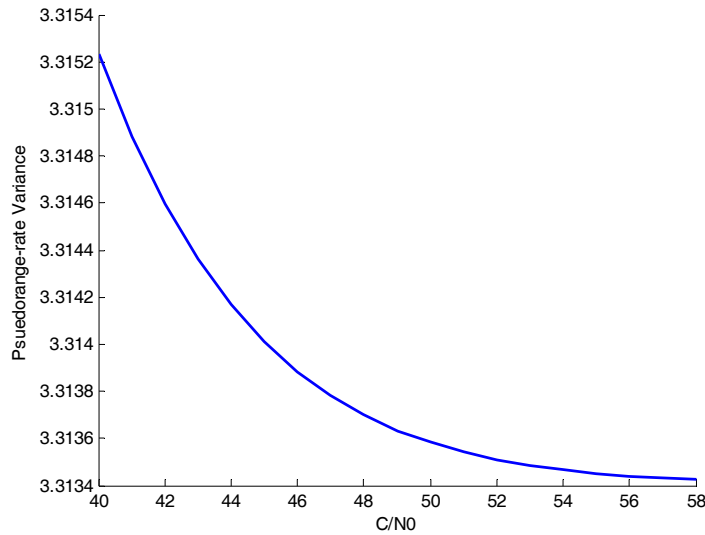

Fig. 3. Covariance Analysis of Vector Tracking method for one satellite (PRN 4).

bandwidth. Typical values in an L1 C/A code GPS receiver, means GPS signal in L1 frequency band (1575.42 MHz) and with the Coarse/Acquisition (C/A) PRN codes, that is related to our work are as follows:

C/N_0 : ~ 37 to 45dB-Hz

The following plots show the results of covariance analysis in MATLAB. In the plot of Fig. 3, the covariance analysis of the vector tracking method for a visible satellite is shown. The covariance of the method joined with MMSE for the same satellite is shown in Fig. 4. The covariances are shown in normalized format to compare them better. The reduction in covariance for the second method is obviously shown in Fig. 5 that the two methods are shown in one figure to compare the performance of the two architectures. To see the complete analysis process and to be more precise, Fig. 6 and Fig. 7 show the results of covariance analysis of each architecture for all the nine visible satellites.

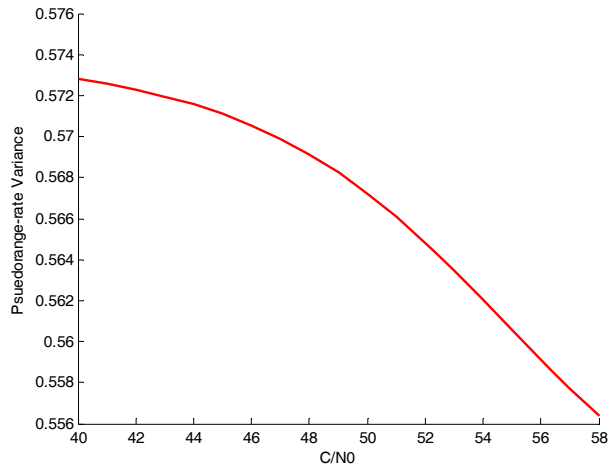

Fig. 4. . Covariance Analysis of Vector Tracking+MMSE method for one satellite (PRN 4).

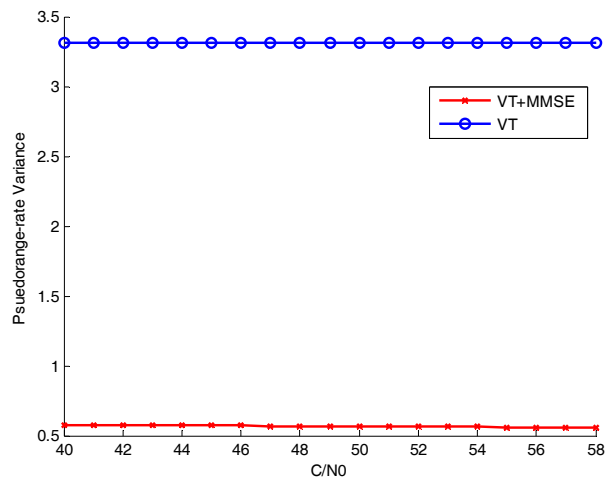

Fig. 5. Comparing the performance of two architectures of Vector Tracking(VT) and Vector Tracking joined with MMSE(VT+MMSE)for one visible satellite of PRN 4.

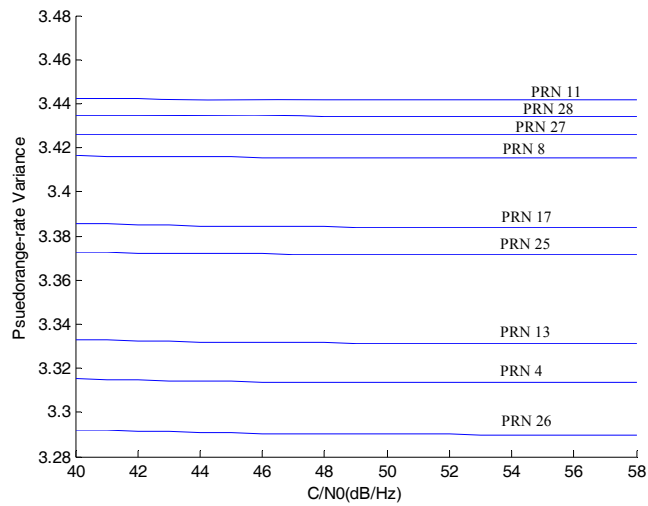

Fig. 6. Covariance Analysis of Vector Tracking for all visible satellites

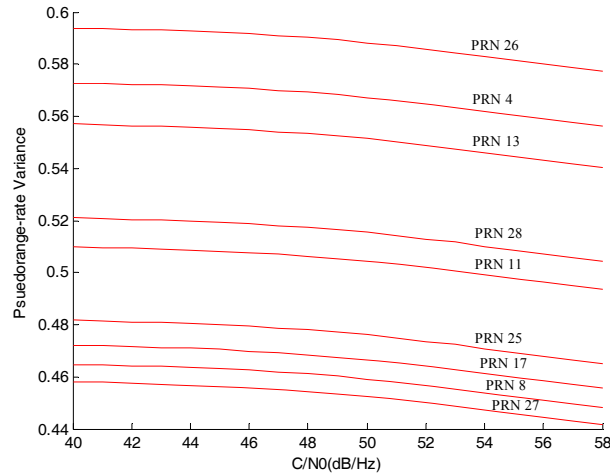

Fig. 7. Covariance Analysis of Vector Tracking + MMSE for all visible satellites

V. DISCUSSION AND CONCLUSION

The results confirm the use of MMSE for better performance gain. The results of variance comparison, show that in the case of using MMSE block in the vector tracking, we obtained smaller variances in the pseudo-range rates. Of course smaller variances means that applying multiuser detection helped the tracking loop for error reduction in tracking process and having more precise tracking results is important in some situation such as high dynamic and low SNR. The work done by Lashley [10] shows the same analysis for comparing the scalar and vector tracking loops. Here, the better tracking loop, means the vector tracking method, is improved in performance by applying a multiuser detector joined with the tracking loop. So using MMSE joined vector tracking loop has smaller variance of pseudo-range rate and therefore better performance in comparison to a conventional vector tracking loop. Of course investigation and analysis of some other parameters such as speed and complexity of the method to prove using MMSE block seems necessary that remains for future works.

REFERENCES

- [1] M. Lashley, D. M. Bevly and J. Y. Hung, "Performance Analysis of Vector Tracking Algorithms for Weak GPS Signals in High Dynamics," *IEEE Journal of Selected Topics in Signal Processing*, vol. 3, no. 4, pp. 661-673 August 2009.
- [2] W.J. Hurd, J.I. Statman, and V.A. Vlnrotter, "High dynamic GPS receiver using maximum likelihood estimation and frequency tracking," *IEEE Trans. Aerospace and Electronic Systems*, vol. 23, no. 4, pp. 425-437, July 1987.
- [3] W. Li, S. Liu, C. Zhou, S. Zhou, and T. Wang, "High Dynamic Carrier Tracking Using Kalman Filter Aided Phase Lock Loop," *International Conference on Wireless Communications, Networking and Mobile Computing, WiCom* 2007.

- [4] K.-H. Kim, G.-I. Jee and J.-H. Song, "Carrier Tracking Loop using the Adaptive Two-Stage," *International Journal of Control, Automation, and Systems*, vol. 6, no. 6, pp. 948-953, December 2008.
- [5] P. A. Roncagliolo, J. G. Garc'ia, and C. H. Muravchik, "Optimized Carrier Tracking Loop Design for Real-Time High-Dynamics GNSS Receivers," *International Journal of Navigation and Observation*, vol. 2012, 18 pages, 2012.
- [6] A. Soloviev, S. Gunawardena, and F. Van Graas, "Mitigation of GPS Cross-Correlation Errors using Semi-Codeless Tracking," *IEEE Trans. Aerospace and Electronic Systems*, vol. 48, no. 1, pp. 502-513, January 2012.
- [7] A. Sreenivas, M.N.V. Pavan Kumar, "An Adaptive Technique for the Mitigation of GPS Cross-Correlation," *International Journal of Engineering Research and Technology*. vol. 2. no. 2 , pp. 1-8, April 2013.
- [8] H. CHEN, W. JIA, and M. YAO, "Cross-Correlation-Function-Based Multipath Mitigation Method for Sine-BOC Signals," *Radioengineering*, vol. 21, no. 2, p. 659-665, June 2012.
- [9] T. Shojaezand, G. R. Mohammad-Khani, and P. Azmi, "Variance Analysis of the New Method of Applying Multiuser Detection in a GPS Receiver in High Dynamic Conditions," *Wireless Personal Communication*, vol. 98, no. 2, pp. 2107-2119, Jan 2018.
- [10] S. Zhao, M. Lu, and Z. Feng, "Implementation and Performance Assessment of a Vector Tracking Method Based on a Software GPS Receiver," *Journal of Navigation*, vol. 64, no. S1, pp. S151-S161, November 2011.
- [11] M. Lashley, D. M. Bevely, and J. Y. Hung, "A valid comparison of vector and scalar tracking loops," *IEEE/ION Position, Location and Navigation Symposium*, Indian Wells, CA, pp. 464-474, 2010.
- [12] G.L. Stuber, "MMSE Linear Multiuser Detection for a DS-CDMA System," *ECE6604, Personal and Mobile Communications*, Spring 2000.
- [13] M. Lashley, "Modeling and Performance Analysis of GPS Vector Tracking Algorithms," Ph.D. dissertation, Dept. Elect. Eng., Auburn University, Alabama, December 18, 2009.
- [14] J. B. Bullock, M. Foss, G. J. Geier, and M. King, "Integration of GPS with other sensors and network assistance," *Understanding GPS: Principles and Applications*, 2nd edition, E. D. Kaplan and C. J. Hegarty, (eds.), Mobile Communication Series, chapter 9, pages 459–558. Artech House Publishers, 2006.
- [15] T. Lacey, "Tutorial: The Kalman Filter," *Computer Vision*, <http://www.cc.gatech.edu/classes/cs7322-98-spring/PS/kf1.pdf>.
- [16] N. A. Othman and H. Ahmad, "The Analysis of Covariance Matrix for Kalman Filter based SLAM with Intermittent Measurement," *Proceedings of the 2013 International Conference on Systems, Control and Informatics*, Pahang, Malaysia, 2013, pp. 227-231.
- [17] R. N. Crane, "A Simplified Method for Deep Coupling of GPS and Inertial Data," *Proceedings of the 2007 National Technical Meeting of The Institute of Navigation*, San Diego, CA, January 2007, pp. 311-319.
- [18] V. B. S. Srilatha Indira Dutt, G. Sasi Bhushana Rao, S. Rani, S. Ravindra Babu, R. Goswami and Ch. Usha Kumari, "Investigation of GDOP for Precise user Position Computation with all Satellites in view and Optimum four Satellite Configurations," *Journal of Indian Geophysics Union*, vol.13, no.3, pp.139-148, July 2009.